



SPLIT TYPE SUBMITTAL

**Model:
TM18HMO**



Model		TM18HMO	
Power supply	Rated Voltage	V~	208/230
	Rated Frequency	Hz	60
	Phases	-	1
Cooling capacity		Btu/h	17000
Heating capacity		Btu/h	18000
Cooling Power Input		W	1420
Heating Power Input		W	1380
Cooling Current Input		A	6.28
Heating Current Input		A	6.12
Rated Power Input		W	2300/2100
Rated Current		A	10.0/9.0
EER		(Btu/h)/W	12.00
COP		(Btu/h)/W	13.03
SEER		-	21.00(SEER) 21.00(SEER2)
HSPF		-	10.00(HSPF) 10.00(HSPF2)
Outdoor Unit	Compressor Trademark	-	ZHUHAI LANDA COMPRESSOR CO., LTD.
	Compressor Model	-	QXF-A139zH170A
	Compressor Refrigerant Oil Type	-	FW68DA or equivalent
	Compressor Type	-	Inverter Rotary
	L.R.A	A	25
	Compressor Rated Load Amp (RLA)	A	9.95
	Compressor Power Input	W	1295
	Suggested Breaker Size	-	15
	Compressor Thermal Protector	-	KSD115°C HPC115/95U1
Throttling Method		-	Electron expansion valve

Job Name:

Schedule Reference:

Date:

Specification are subject to change without notice.



TOSOT

WWW.TOSOTCOMFORT.COM

Outdoor Unit	Cooling Operation Ambient Temperature Range	°F	-22~118
	Heating Operation Ambient Temperature Range	°F	-22~75.2
	Condenser Material	-	Aluminum Fin-copper Tube
	Condenser Pipe Diameter	mm	Φ7.94
	Rows-Fin Gap(mm)	mm	2-1.4
	Coil length (l) × height (H) × coil width (L)	mm	834 × 528 × 38.1
	Fan Motor Speed (rpm)	rpm	cooling:900 heating:900
	Output of Fan Motor	W	30
	Fan Motor RLA	A	/
	Fan Motor Capacitor	μF	/
	Air Flow Volume of Outdoor Unit	CFM	1354
	Fan Type-Piece	-	Axial-flow
	Fan Diameter	mm	Φ420-131.1
	Defrosting Method	-	Automatic Defrosting
	Climate Type	-	T1
	Isolation	-	I
	Moisture Protection	-	IPX4
	Permissible Excessive Operating Pressure for the Discharge Side	PSIG	550
	Permissible Excessive Operating Pressure for the Suction Side	PSIG	240
	Dimension (W × D × H)	inch	32 23/64 × 13 55/64 × 21 21/32
	Dimension of Package (L × W × H)	inch	34 7/32 × 15 35/64 × 23 25/64
	Dimension of Package(L × W × H)	inch	34 21/64 × 15 43/64 × 24 13/32
	Net Weight	lb	77.2
	Gross Weight	lb	82.7
	Refrigerant Charge	-	R410A
	Refrigerant Charge	oz	45.9
	Cross-sectional Area of Power Cable Conductor	sq in	0.0032(AWG14)
	Recommended Power Cable(Core)	N	3
	Connection Pipe Connection Method	-	Flare Connection
	Not Additional Gas Connection Pipe Length	ft	32.8
	Connection Pipe Gas Additional Charge	oz/ft.	0.2
	Outer Diameter of Liquid Pipe1 (GREE Allocation)(Metric)	inch	1/4"
	Outer Diameter of Liquid Pipe2(GREE Allocation)(Metric)	inch	1/4"
Outer Diameter of Gas Pipe1 (GREE Allocation)(Metric)	inch	3/8"	
Outer Diameter of Gas Pipe2(GREE Allocation)(Metric)	inch	3/8"	
Connection Pipe Max. Height Distance(indoor and indoor)	ft	49.	
Connection Pipe Max. Height Distance(indoor and outdoor and indoor up)	ft	49.	
Connection Pipe Max. Height Distance(indoor and outdoor and outdoor up)	ft	49.2	
Max. equivalent connection pipe length(outdoor to last indoor)	ft	65.6	
Connection Pipe Max. Length Distance(total length)	ft	131.2	

The above data is subject to change without notice; please refer to the nameplate of the unit.

Job Name:

Schedule Reference:

Date:

Specification are subject to change without notice.



TOSOT
WWW.TOSOTCOMFORT.COM

MODEL NUMBER	POSSIBLE COMBINATIONS	COOLING CAPACITY (Btu/h)					COOLING CAPACITY (Btu/h)				
		ZONE1	ZONE2	ZONE3	ZONE4	ZONE5	ZONE1	ZONE2	ZONE3	ZONE4	ZONE5
TM18HMO	9k+9k	8,500	8,500				9,000	9,000			
TM18HMO	9k+12k	7,286	9,714				7,714	10,286			
TM18HMO	12k+12k	8,500	8,500				9,000	9,000			



TOSOT

WWW.TOSOTCOMFORT.COM

Outline and Physical Dimensions of TM18HMO.

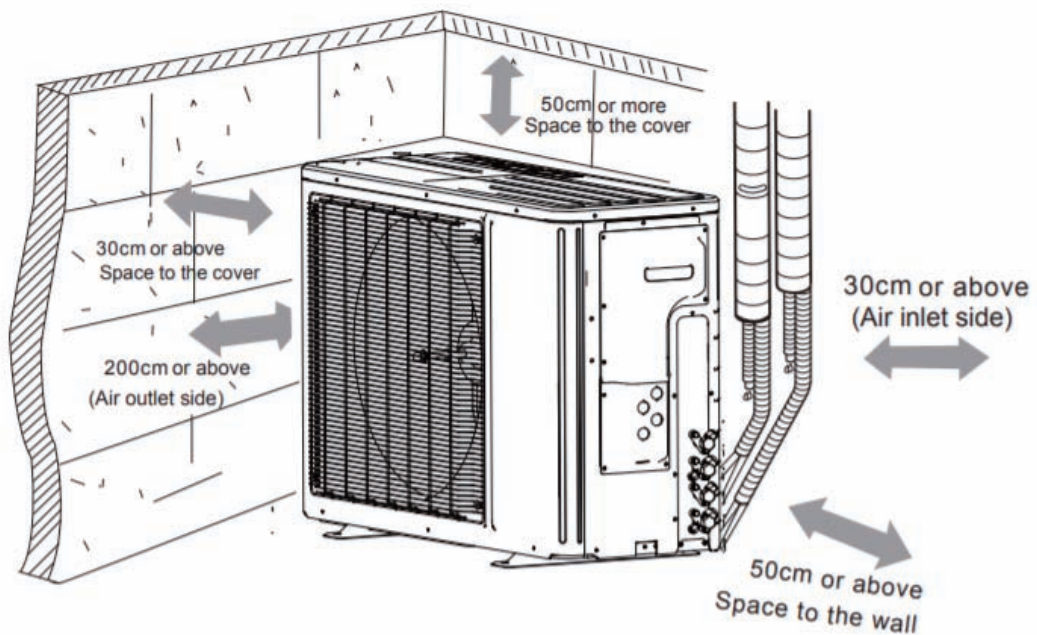
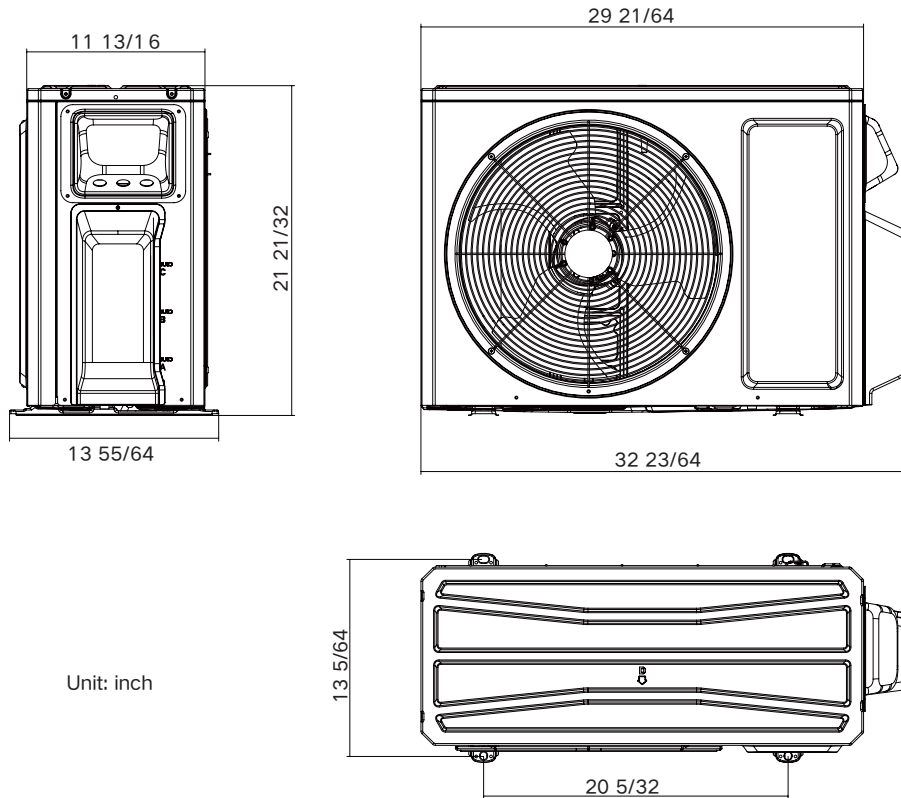

TOSOT COMFORT INC.

E-mail: HI@tosotcomfort.com www.tosotcomfort.com