



SPLIT TYPE



SUBMITTAL

**Model:
TM30HMO**



Model		TM30HMO	
Power supply	Rated Voltage	V~	208/230
	Rated Frequency	Hz	60
	Phases	-	1
Cooling capacity		Btu/h	28400
Heating capacity		Btu/h	30000
Cooling Power Input		W	2270
Heating Power Input		W	2250
Cooling Current Input		A	10.07
Heating Current Input		A	9.98
Rated Power Input		W	4600/5000
Rated Current		A	20.41/21.74
EER		(Btu/h)/W	12.49
COP		(Btu/h)/W	13.34
SEER		-	21.00(SEER) 21.00(SEER2)
HSPF		-	10.00(HSPF) 10.00(HSPF2)
Outdoor Unit	Compressor Trademark	-	ZHUHAI LANDA COMPRESSOR CO., LTD.
	Compressor Model	-	QXFS-B238zX070
	Compressor Refrigerant Oil Type	-	FW68DA or equivalent
	Compressor Type	-	Inverter Rotary
	L.R.A	A	/
	Compressor Rated Load Amp (RLA)	A	14.25
	Compressor Power Input	W	2047
	Suggested Breaker Size	-	25
	Compressor Thermal Protector	-	KSD115°C HPC115/95U1
Throttling Method		-	Electron expansion valve

Job Name:

Schedule Reference:

Date:

Specification are subject to change without notice.



Outdoor Unit	Cooling Operation Ambient Temperature Range	°F	-22~118
	Heating Operation Ambient Temperature Range	°F	-22~75.2
	Condenser Material	-	Aluminum Fin-copper Tube
	Condenser Pipe Diameter	mm	Φ7.94
	Rows-Fin Gap(mm)	mm	2-1.4
	Coil length (l) × height (H) × coil width (L)	mm	1066 × 792 × 38.1
	Fan Motor Speed (rpm)	rpm	cooling:860 heating:860
	Output of Fan Motor	W	130
	Fan Motor RLA	A	/
	Fan Motor Capacitor	-	/
	Air Flow Volume of Outdoor Unit	CFM	3413
	Fan Type-Piece	-	Axial-flow
	Fan Diameter	mm	Φ550-205
	Defrosting Method	-	Automatic Defrosting
	Climate Type	-	T1
	Isolation	-	I
	Moisture Protection	-	IPX4
	Permissible Excessive Operating Pressure for the Discharge Side	PSIG	550
	Permissible Excessive Operating Pressure for the Suction Side	PSIG	240
	Dimension (W × D × H)	inch	40 5/32 × 16 13/16 × 32 33/64
	Dimension of Package (L × W × H)	inch	42 29/32 × 19 29/64 × 34 1/4
	Dimension of Package(L × W × H)	inch	43 1/32 × 19 9/16 × 34 27/32
	Net Weight	lb	152.1
	Gross Weight	lb	167.6
	Refrigerant Charge	-	R410A
	Refrigerant Charge	oz	105.8
	Cross-sectional Area of Power Cable Conductor	sq in	0.008215(AWG10)
	Recommended Power Cable(Core)	N	3
	Connection Pipe Connection Method	-	Flare Connection
	Not Additional Gas Connection Pipe Length	ft	131.2
	Connection Pipe Gas Additional Charge	oz/ft.	0.2
	Outer Diameter of Liquid Pipe1(GREE Allocation)(Metric)	inch	1/4"
	Outer Diameter of Liquid Pipe2(GREE Allocation)(Metric)	inch	1/4"
	Outer Diameter of Liquid Pipe3(GREE Allocation)(Metric)	inch	1/4"
	Outer Diameter of Liquid Pipe4(GREE Allocation)(Metric)	inch	1/4"
	Outer Diameter of Gas Pipe1(GREE Allocation)(Metric)	inch	3/8"
	Outer Diameter of Gas Pipe2(GREE Allocation)(Metric)	inch	3/8"
	Outer Diameter of Liquid Pipe3(GREE Allocation)(Metric)	inch	3/8"
	Outer Diameter of Liquid Pipe4(GREE Allocation)(Metric)	inch	3/8"
	Connection Pipe Max. Height Distance(indoor and indoor)	ft	82.0
Connection Pipe Max. Height Distance(indoor and outdoor and indoor up)	ft	82.0	
Connection Pipe Max. Height Distance(indoor and outdoor and outdoor up)	ft	82.0	
Max. equivalent connection pipe length(outdoor to last indoor)	ft	82.0	
Connection Pipe Max. Length Distance(total length)	ft	262.5	

The above data is subject to change without notice; please refer to the nameplate of the unit.

Job Name:

Schedule Reference:

Date:

Specification are subject to change without notice.



MODEL NUMBER	POSSIBLE COMBINATIONS	COOLING CAPACITY (Btu/h)					COOLING CAPACITY (Btu/h)				
		ZONE1	ZONE2	ZONE3	ZONE4	ZONE5	ZONE1	ZONE2	ZONE3	ZONE4	ZONE5
TM30HMO	9k+9k	9,000	9,000				9,500	9,500			
TM30HMO	9k+12k	9,000	12,000				9,429	12,571			
TM30HMO	9k+18k	9,000	18,000				9,000	18,000			
TM30HMO	9k+24k	7,745	20,655				8,182	21,818			
TM30HMO	12k+12k	12,000	12,000				12,000	12,000			
TM30HMO	12k+18k	11,360	17,040				12,000	18,000			
TM30HMO	12k+24k	9,467	18,933				10,000	20,000			
TM30HMO	18k+18k	14,200	14,200				15,000	15,000			
TM30HMO	18k+24k	12,171	16,229				12,857	17,143			
TM30HMO	9k+9k+9k	9,000	9,000	9,000			9,000	9,000	9,000		
TM30HMO	9k+9k+12k	8,520	8,520	11,360			9,000	9,000	12,000		
TM30HMO	9k+9k+18k	7,100	7,100	14,200			7,500	7,500	15,000		
TM30HMO	9k+9k+24k	6,086	6,086	16,229			6,429	6,429	17,143		
TM30HMO	9k+12k+12k	7,745	10,327	10,327			8,182	10,909	10,909		
TM30HMO	9k+12k+18k	6,554	8,738	13,108			6,923	9,231	13,846		
TM30HMO	9k+12k+24k	5,680	7,573	15,147			6,000	8,000	16,000		
TM30HMO	9k+18k+18k	5,680	11,360	11,360			6,000	12,000	12,000		
TM30HMO	12k+12k+12k	9,467	9,467	9,467			10,000	10,000	10,000		
TM30HMO	12k+12k+18k	8,114	8,114	12,171			8,571	8,571	12,857		
TM30HMO	9k+9k+9k+9k	7,100	7,100	7,100	7,100		7,500	7,500	7,500	7,500	
TM30HMO	9k+9k+9k+12k	6,554	6,554	6,554	8,738		6,923	6,923	6,923	9,231	
TM30HMO	9k+9k+9k+18k	5,680	5,680	5,680	11,360		6,000	6,000	6,000	12,000	
TM30HMO	9k+9k+12k+12k	6,086	6,086	8,114	8,114		6,429	6,429	8,571	8,571	
TM30HMO	9k+12k+12k+12k	5,680	7,573	7,573	7,573		6,000	8,000	8,000	8,000	



Outline and Physical Dimensions of TM30HMO.

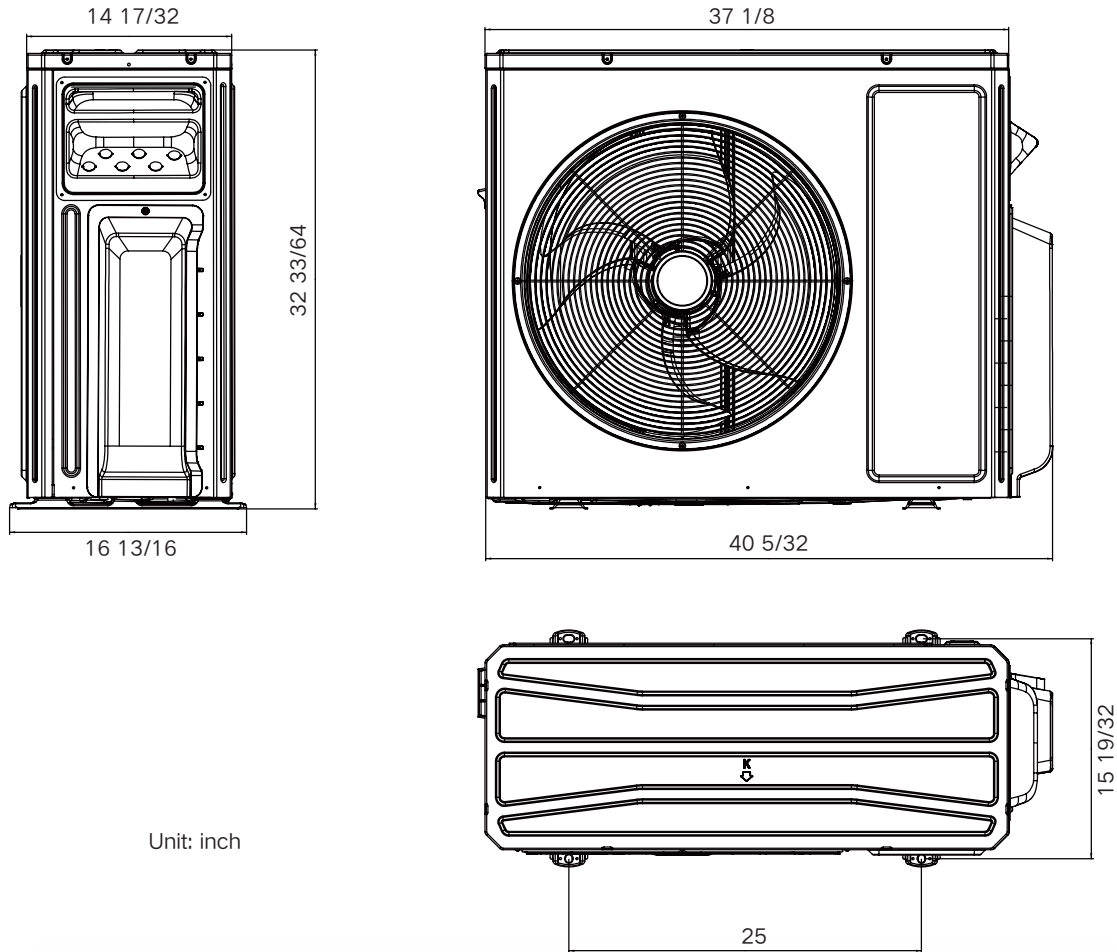

Unit: inch

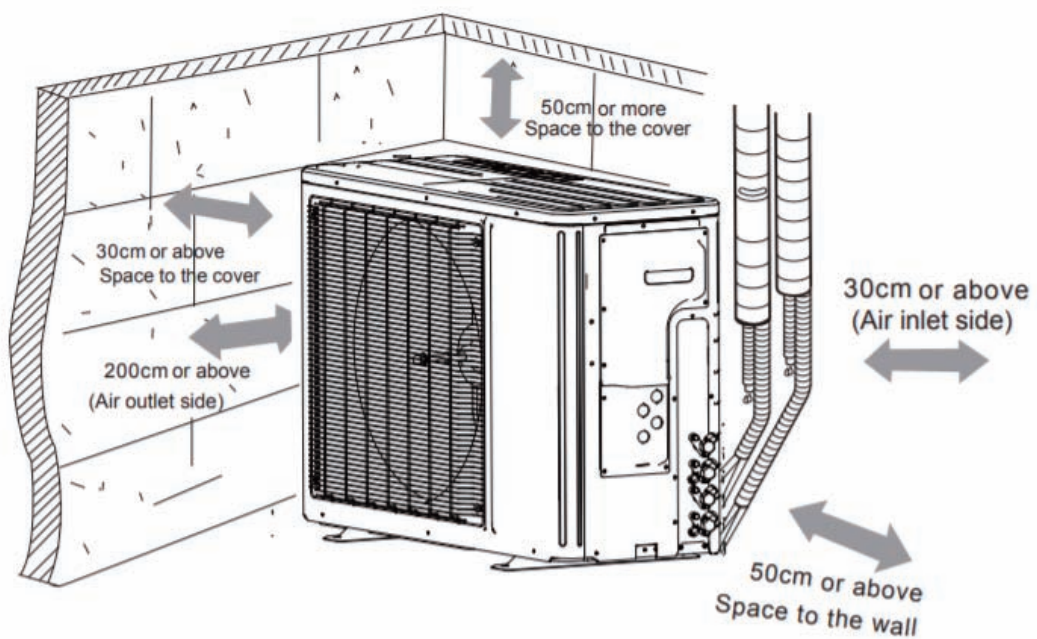

TOSOT COMFORT INC.

E-mail: HI@tosotcomfort.com www.tosotcomfort.com