

End-of-Arm-Tooling solutions for material handling

Perfectly tailored to your robot applications



Table of contents

Our offer – Your benefits

End-of-Arm-Tooling solutions for all robot applications 3

Complete solution for robot applications

End-of-Arm-Tooling & robotic tool changers 4

End-of-Arm-Tooling solution competence

Broad technology portfolio from a single source 6

Flexible and durable systems – local to you, throughout the world 7

Always a tailored solution for your requirements 9

Robotic tool changers

Automatic robotic tool changers 10

Manual robotic tool changers 11

Material handling

End-of-Arm-Tooling components for gripper technology 12

Profiles and union joints 14

Grippers 20

Air nippers and air shears 26

Vacuum suction cups 30

Area grippers 35

Vacuum generation 36

Electronics and sensors 38

OUR OFFER – YOUR BENEFITS

End-of-Arm-Tooling solutions for all robot applications

Stäubli offers comprehensive and highly flexible tool changing and End-of-Arm-Tooling solutions for material handling in all automated manufacturing processes. This includes automatic and manual robotic tool changing systems as well as a broad tooling portfolio that makes technologies such as gripping, suction and cutting available from a single source for all robots worldwide.



THE BENEFITS



Always a tailored solution for your requirements



Broad technology portfolio for material handling from a single source



Flexible and durable systems for lasting productivity



The highest quality of advice and service, local to you, throughout the world

COMPLETE SOLUTION FOR ROBOT APPLICATIONS

End-of-Arm-Tooling & robotic tool changers



All robots

Direct mounting, automatic tool changer or manual tool changer

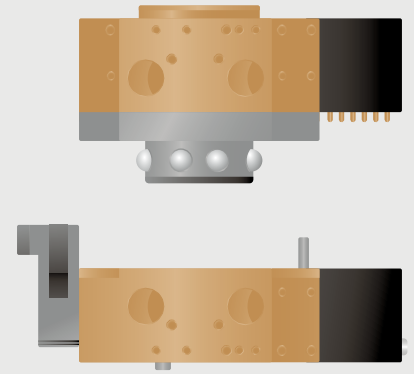

Grippers

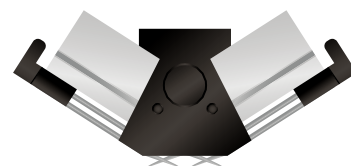
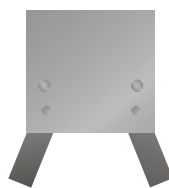
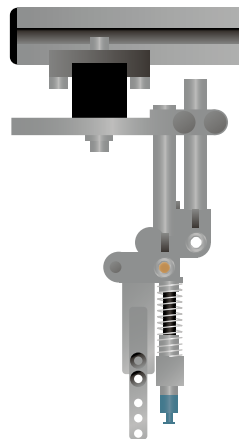
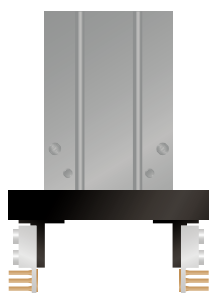

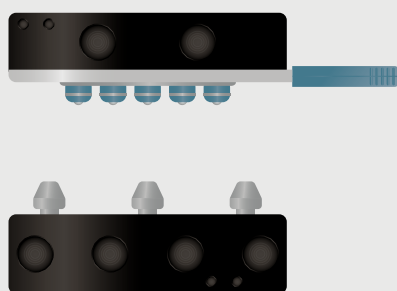

Gripping systems

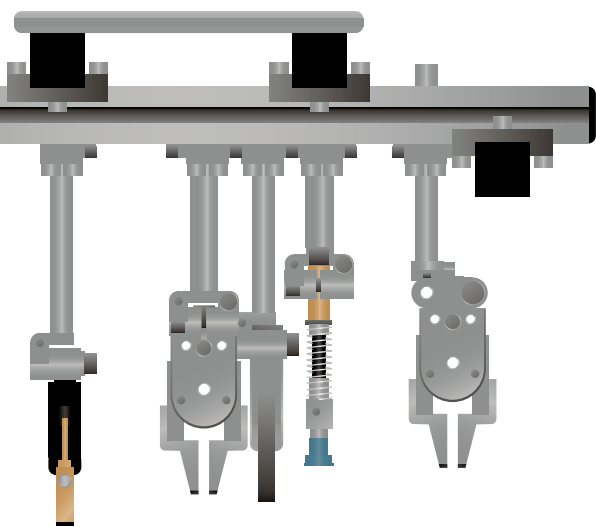

Suctions

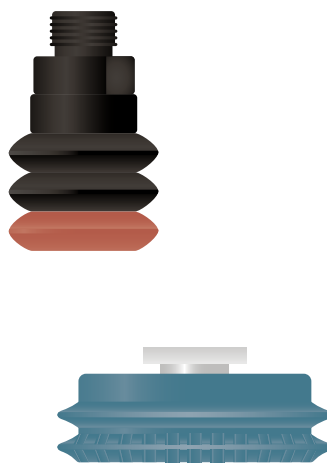

Cuttings

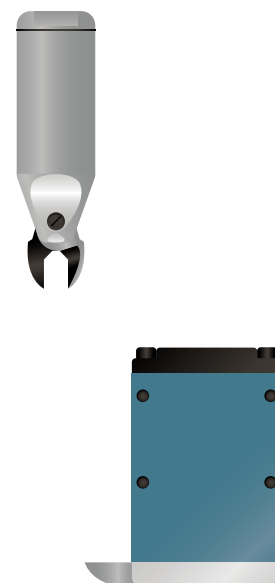

Broad technology portfolio from a single source



Gripping, suction and tool change - all technologies from a single source

The combined use of mechanical gripping and vacuum suction – often together with tool changing systems – is an everyday requirement in material handling. Stäubli offers you the entire End-of-Arm-Tooling spectrum required – from a single source and for all robots worldwide.

Whether plant developer or plant operator: This wide range of products means that you receive all the necessary components for your End-of-Arm-Tooling from a single specialist.

Ideally matched End-of-Arm-Tooling components

You reduce your interfaces and reduce risks such as mutually restrictive functionality, reduced service life or additional adjustment effort that can arise from using components from many different sources that are not matched to each other.

The comprehensive expertise of our strategic cooperation partner FIPA is reflected in this Stäubli offer. FIPA is an internationally active company specialising in the development and manufacture of quality products and innovative system solutions for handling processes.



Flexible and durable systems – local to you, throughout the world

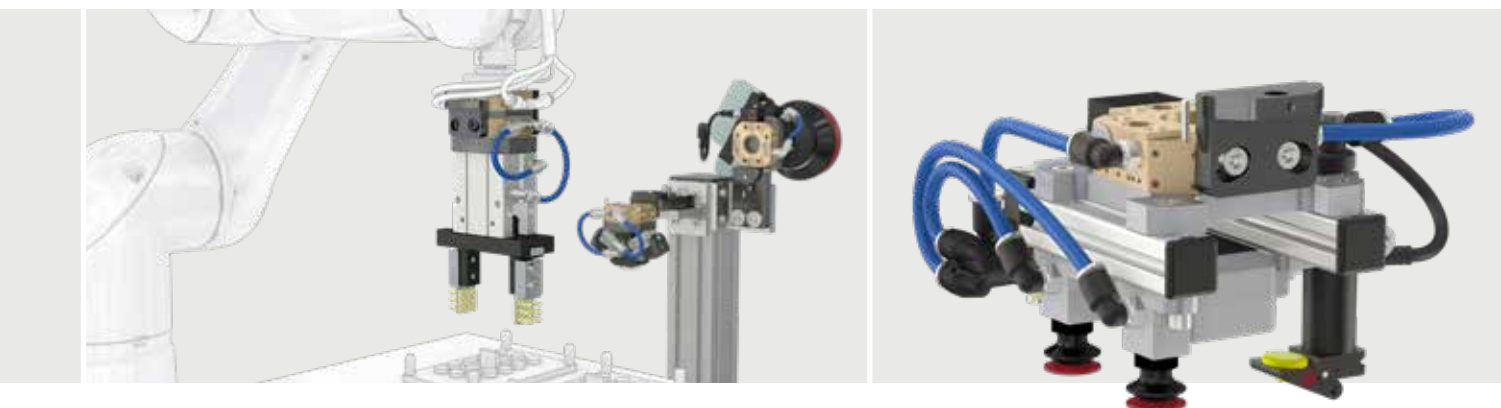

Sustainable productivity

The durability and flexibility of the solution are critical to the long-term return on investment of your End-of-Arm-Tooling.

Stäubli stands for high-precision and high-quality products with a long service life. The flexibility of our solutions ensures the long-term usability of your investment over this long period – even if your processes and requirements change. Our systems can be adapted to new conditions at any time, for example within the scope of a retooling or retrofit.

Stäubli is your expert for sustainable productivity in End-of-Arm-Tooling.



Local to you, throughout the world

Stäubli is represented by subsidiaries in all industrial centres around the globe. There, experienced engineers have detailed, product-specific expertise and application knowledge. This guarantees our clients the highest quality of advice everywhere.

Thanks to the close networking of our locations, we can implement comprehensive End-of-Arm-Tooling concepts for you and establish globally uniform standards. You receive solutions that take into account all country-specific guidelines and standards.



END-OF-ARM-TOOLING SOLUTION COMPETENCE

Always a tailored solution for your requirements



Customer-specific End-of-Arm-Tooling solutions

Need an experienced partner for the conception of your End-of-Arm-Tooling? Your process requires an individually combined solution that is precisely tailored to your robot applications? Need advice on the use of individual End-of-Arm-Tooling components?

Stäubli's experienced project planning team will be happy to support you at any time in developing the perfect solution for your requirements.

Overall planning and delivery of all components

We take over the complete definition and CAD planning of the entire system for you, based on your general conditions and application requirements.

If you would like to carry out the final assembly yourself, we will provide you with all the components required for implementation, including the necessary drawings and descriptions.

All-round service including assembly

Or you can opt for our complete solution, which we deliver fully assembled. Then all that remains to be done on site is the final fine-tuning.

Let us find your solution.

ROBOTIC TOOL CHANGERS

Automatic robotic tool changers

Technical description

- Automatic connection between robot and gripper
- Modular product concept
- Numerous transfer modules
- Docking station available as option
- Safety function for Performance Level d, Category 3



	Small payloads				Mid payloads			High payloads		
Series	MPS 015	MPS 025	MPS 035	MPS 055	MPS 080	MPS 130	MPS 260	MPS 631	MPS 1530	MPS 2531
Max. payload (kg)	10	20	35	55	80	100	350	630	1530	2500
Flange sizes in accordance with ISO9401-1 (mm)	31.5	40	50	63	80	100	125	160 / 200	160 / 200	315

Manual robotic tool changers

Technical description

- Manual connection between robot and gripper
- Round and square design
- Standardised sizes
- Electric plug for SR series available as option
- SAFE-LOCK and micro valves available as option for SR series



	SR series, round design			S-series, square design			
Series	SR 050	SR 090	SR 150	S 060	S 100	S 160	S 250
Max. payload (kg)	20	40	100	5	10	20	40
External Ø (mm)	50	90	150	–	–	–	–
Dimensions (mm)	–	–	–	60 x 60	100 x 100	160 x 160	250 x 250
Optional micro valves	Yes	Yes	No	–	–	–	–

MATERIAL HANDLING

End-of-Arm-Tooling components for gripper technology

Profiles and union joints



From page 14

Grippers



From page 20

Air nippers and air shears



From page 26

Vacuum suction cups



From page 30

Area grippers



From page 35

Vacuum generation



From page 36

Electronics and sensors



From page 38

Profiles and union joints

Aluminium profiles

Technical description

- Aluminium profiles
- Material: AlMgSi 0.5 F25
- Special length over 2000 mm on request



Profile type	Height (mm)	Width (mm)	Sketch
SLine	20	20	
	20	40	
	40	40	
JLine	40	40	
	40	80	
MLine	25	25	
	25	50	
XLine	40	40	
	40	80	
	80	80	

Union joints

Technical description

- For the stable connection of profiles
- Various versions available
- Connections for grippers and suction cups



Designation	SLine	JLine	MLine	XLine
90° joining plate	Yes	No	Yes	No
90° - 130° corner joint plate	Yes	Yes	Yes	Yes
0 - 90° profile connector	Yes	Yes	Yes	Yes
90° angle connector with cover	Yes	No	Yes	Yes
90° profile end connector	Yes	No	Yes	Yes
Straight connector	No	No	No	Yes
L-shaped flat connector	Yes	Yes	Yes	Yes
T-shaped flat connector	Yes	Yes	Yes	Yes
45° connector	Yes	Yes	Yes	No
Cross joint connector basic	No	No	Yes	No
Cross joint connector	Yes	Yes	Yes	Yes
Profile connector	Yes	Yes	Yes	No
Rotatable profile connector	Yes	No	Yes	No
Heavy-duty clamp*	Yes	Yes	Yes	No
Cross clamps*	Yes	No	Yes	Yes
Cross clamp with ball joint**	Yes	No	Yes	No
Profile tube adaptor**	Yes	No	Yes	No

* For clamp diameters 10, 14, 20 and 30 mm.

** For clamp diameters 10, 14 and 20 mm.

MATERIAL HANDLING

Gripper arms

Technical description

- Fastening and integrating suction and gripper components into gripper systems
- Spring-loaded components with anti-twist device ensure that handling is gentle on the workpiece and safe for the process
- Spring-loaded components absorb the stroke during the ejection movement of the injection moulding machine, for example
- Elbow arms and suction fingers available in rigid or swivelling versions

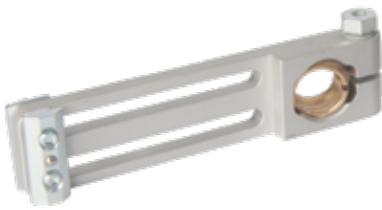

Designation	SLine	JLine	MLine	XLine
Short angle clamp*	Yes	No	Yes	Yes
Long angle clamp*	Yes	No	Yes	Yes
Angle clamp, space-saving*	No	Yes	Yes	No
Angle clamp, long, heavy duty*	No	Yes	Yes	No
Angle clamp, reinforced, with ball joint and swivel head**	No	Yes	Yes	No
Angle clamp with thread	Yes	No	Yes	No
Angle clamp with ball joint*	Yes	No	Yes	Yes
Angle clamp with swivel head*	Yes	Yes	Yes	Yes
Angle clamp short for vacuum suction cup	No	No	No	Yes
Angle clamp long for vacuum suction cup	Yes	No	Yes	No
Angled fitting 360° rotatable	Yes	No	Yes	No
Angle connector, swiveling	Yes	No	Yes	No
Angle connector, lateral	Yes	No	Yes	No

* For clamp diameters 10, 14, 20 and 30 mm.

** For clamp diameters 10, 14 and 20 mm.

Parallel clamps, round profile and cross clamp round profile 90° optionally available.



Designation	Shaft or stroke length (mm)	Clamping Ø (mm)	Options	
			Rigid	Swivel
Elbow arms	15 - 200	10, 14, 20, 30	Yes	Yes
Spring-compensated, non-rotating elbow arms	10 - 40	10, 14, 20	Yes	Yes
Elbow arm heavy-duty	30 - 150	10, 14, 20	No	Yes
Elbow arm extra heavy-duty	30 - 200	10, 14, 20, 30	No	Yes
Suction finger	30 - 200	10, 14, 20, 30	Yes	Yes
Suction finger, spring loaded	10 - 40	10, 14, 20	Yes	No
Suction finger, spring-loaded, non-rotating	10 - 40	10, 14, 20	Yes	Yes
Gripper arm, spring-loaded for sprue grippers	15 - 20	14, 20	Yes	No



Designation	Stroke (mm)	Options			
		Anti-twist	Not anti-twist	Internal spring	External Spring
Spring leveler external thread	7 - 80	Yes	Yes	Yes	Yes
Spring leveler clamping body	10 - 50	Yes	No	Yes	No
Spring leveler snap-in	5 - 49.5	Yes	Yes	Yes	Yes

MATERIAL HANDLING

Accessories for profiles and union joints

Technical description

- Air-vacuum manifolds in multiple versions for easy set-up of compressed air or vacuum systems
- Locator pin for better positioning of the gripper in the tool
- Pneumatic centring unit for precise positioning and fastening of the gripper in the tool
- Slot nuts in various sizes and designs for secure fastening of the attachments to the profiles



Designation	SLine	JLine	MLine	XLine
Air-vacuum manifolds	Yes	Yes	Yes	No
Stackable air-vacuum manifolds	Yes	Yes	Yes	No
Locator pin	Yes	Yes	Yes	Yes
Swivel slot nuts, ball joint optional	Yes	No	No	Yes

Pneumatic centring unit with clamping diameter 14 and 20 mm, centring pins with clamping diameter 10, 14, 20 and 30 mm optionally available.

Linear technology

Technical description

- Double-acting linear components
- Precise positioning of gripper components and vacuum cups on gripper systems
- PNP/NPN sensor for sensing the working position optionally available



Designation	Piston Ø (mm)	Stroke (mm)
Dual-piston cylinders	12	25; 50; 75
	16	25; 50; 75; 100



Designation	Piston Ø (mm)	Stroke (mm)
Guide blocks	8	30; 50; 75
	16	30; 50; 75; 100
	20	10; 30; 50; 75; 100; 125; 150
	6*	10; 20; 30
	10*	10; 20; 30
	16*	10; 20; 30

* Extra narrow design



Designation	Piston Ø (mm)	Stroke (mm)
Short-stroke cylinders	12	5; 10
	16	5; 10; 20; 30
	20	5; 10; 20; 30; 50
	25	5; 10; 20; 30; 50
	32	5; 10; 15; 20; 25; 30; 35; 40; 50

Grippers

Sprue grippers

Technical description

- Full range from the smallest gripper to the power gripper
- Micro grippers for very tight spaces
- Power gripper with very high closing force
- Variety of different jaw forms



Designation	Clamping Ø (mm)	Closing force at 6 bar (N)	Optional sensor system PNP/NPN	Working principle
60 series	10	3.5	No	Single-acting
80 series	10	12	No	Single-acting
90 series	10	15	Yes	Single-acting
100 series	10	22	Yes	Single-acting or double-acting
110 series	Direct mounting	66 - 95	Yes	Single-acting or double-acting
120 series	Direct mounting	83	Yes	Single-acting
130 series	20	95	Yes	Single-acting
2016 series	20	52	Yes	Single-acting, self-centring
325 series	20	365	Yes	Single-acting
332 series	20	310	Yes	Double-acting

Gripper finger

Technical description

- Five different opening angles available
- Single-acting with return spring
- Gentle surface gripping with HNBR elastomer pads at 95° gripper finger optionally available
- Stop element with HNBR for 95° gripper finger optionally available
- Gentle surface gripping with HNBR, NBR, silicone or FKM optionally available for angle grippers
- Housing and jaws made of anodised aluminium alloy
- PNP/NPN sensors optionally available for all models



Designation	Opening angle	Clamping Ø (mm)	Closing force at 6 bar (N)
22° compact gripper	22°	20	50-51
25° compact gripper	25°	14	18
35° gripper finger	35°	14	23
		20	65
		30	214
90° gripper finger	90°	14	44
		20	110
		30	240
95° gripper finger	95°	14	24
		20	70
		30	135
90° Swivelling unit	90°	30	276

Different jaw shape variants available.

MATERIAL HANDLING

Parallel grippers

Technical description

- Gripper with high grip force
- Housing made of high-strength aluminium alloy
- Base jaws made of steel, for adapting standard or customer-specific gripper jaws
- Medium: filtered and oiled/unoiled air
- PNP/NPN based sensor system available as option



Piston Ø (mm)	Stroke per gripper jaw (mm)	Gripping force at 6 bar (N)	Working principle
10	2	11-15	Single-acting or double-acting
16	3	33-40	Single-acting or double-acting
20	5	40-49	Single-acting or double-acting
25	7	55-75	Single-acting or double-acting
32	11	152-179	Single-acting or double-acting
40	15	248-285	Single-acting or double-acting
16	4	102	Double-acting

Angle grippers

Technical description

- Angle grippers for gripping at undercuts or for clamping components
- Single-acting and for short cycle times double-acting variants available
- Integrated protective covers
- Housing made of high-strength aluminium alloy
- Base jaws made of steel, for adapting standard or customer-specific gripper jaws
- PNP/NPN based sensor system available as option



Designation	Piston Ø (mm)	Angular stroke per gripper jaw (°)	Gripping force at 6 bar (Ncm)	Opening force at 6 bar (Ncm)	Gripping torque (Nm)
2-finger, 40° angular grippers	10	-10 to +30	11	15	–
	16	-10 to +30	47	65	–
	20	-10 to +30	100	135	–
	25	-10 to +30	199	252	–
	32	-10 to +30	358	476	–
2-finger, 180° angular grippers	10	180 - 182	–	–	0.16
	16	180 - 182	–	–	0.54
	20	180 - 182	–	–	1.1
	25	180 - 182	–	–	2.28

MATERIAL HANDLING

3 finger grippers

Technical description

- Grippers with high grip force
- Compact, flat design
- Double-acting for internal and external gripping and short cycle times
- Housing made of high-strength aluminium alloy
- Base jaws made of steel, for adapting standard or customer-specific gripper jaws
- PNP/NPN based sensor system available as option



Piston Ø (mm)	Stroke per gripper jaw (mm)	Closing force at 6 bar (N)	Opening force at 6 bar (N)
16	2	19	21
25	3	58	64
32	4	98	110
40	5	165	178
50	6	247	270
63	8	425	425
80	10	650	655

Inner grippers

Technical description

- Single-acting expansion grippers with high holding force
- Simple and non-destructive bellows replacement
- Bellows not inflated, thus no danger of bursting
- Gripping bellows function variable: Downward or upward movement of the piston via different clamping points on the housing



For parts with inner Ø (mm)	Elastomer (bellows)
8 - 10	EPDM or silicone
10.5 - 13	EPDM or silicone
13 - 17	EPDM or silicone
15 - 19	EPDM or silicone
19 - 23.5	EPDM or silicone

No sale to Italy, San Marino or USA.

Needle grippers

Technical description

- Grippers for materials that are not dimensionally stable or difficult to pick up with suction
- Stroke limitation through spacer plates
- Crossing of the needles in the middle for a secure hold
- Double-acting for short cycle times
- Needle block fully exchangeable



Stroke (mm)	Number of needles	Needle Ø (mm)	Penetration angle (°)
2.5	12	2	30
4	12	2	30
6	12	2	30

Air nippers and air shears

Air nippers

Technical description

- For cutting and separating plastic sprues or metal wires
- A wide range of cutting inserts covers a great variety of individual applications
- Integration directly into the gripper, in cutting stations or for manual operation
- Cutting blades not included in scope of delivery, please order separately



Housing form	Max. cutting force (N)
Round*	294
Round*	329
Round*	490
Round*/**	588
Round*/**	1372
Round*/**	2744
Round*/**	4704
Square	294
Square	392
Square	490
Square	588
Square	1372
Square	2744

* Also available as manual cutting nippers with safety lever.

** Various clamps and gripper holders available.

Stationary air nippers

Technical description

- Light and compact design of air nippers for installation in confined spaces
- Suitable for cutting stations or automatic machines
- Mounting holes on three sides
- Cutting blades not included in scope of delivery, please order separately
- Optionally available without stroke



Housing form	Max. cutting force (N)	Stroke (mm)
Stationary, vertical with stroke	147	0 - 3
Stationary, vertical with stroke	196	0 - 3
Stationary, vertical with stroke	441	0 - 3
Stationary, vertical with stroke	931	0 - 8
Stationary, horizontal with stroke*	343	0 - 3
Stationary, horizontal with stroke*	490	0 - 3
Stationary, horizontal with stroke*	784	0 - 3
Stationary, horizontal with stroke	980	0 - 5

* Also available without function stroke.

MATERIAL HANDLING

Air nipper accessories

Blades for plastic, L-shape



Blades for plastic, laterally facing



Blades for plastic, Z-shape



Blades for plastic and metal, straight



Blades for plastic, angled



Blades for plastic, nipper style



Fits	Suitable for	Cutting nippers shape	Max. cutting thickness (mm)
Air nippers	Plastic	Nipper style	2 - 12
	Plastic	Straight / Straight extra long	2 - 15
	Plastic	Angled	2 - 18
	Plastic	L-shape	5 - 10
	Plastic	Laterally facing	8x1 / 15x2
	Plastic	Z-shape	5 - 10
	Metal	Straight	0.5 - 5.5
	Metal	Angled	0.5 - 5.5
Stationary air nippers	Plastic	Nipper style	1.5 - 3.5
	Plastic	Straight	1 - 5
	Plastic	Z-shape	2 - 5
	Metal	Straight	1 - 1.6

Air shears

Technical description

- Air shears for use on robots, automatic cutting machines or manual operation
- For paper, foils, steel wire or copper wire, etc.
- Separate compressed air connections for opening and closing for short cycle times
- Continuous cutting process, as no cutter return spring is required
- Cutting blades not included in scope of delivery, please order separately



Housing form	Working principle	Max. cutting thickness Steel strip (mm)	Max. cutting thickness Kevlar (mm)	Max. cutting thickness Copper wire (mm)	Max. cutting thickness Steel wire (mm)
Round	Manual / single-acting	15x0.5	1	–	–
Round	Automatic / double-acting	–	–	1.8	1.2
Square	Automatic / single-acting	–	1	–	–
Square	Automatic / double-acting	–	–	1.8	1.2

Air shears accessories

Blades for double-action air shears



Max. cutting opening (mm)	Effective cutting length (mm)	Max. cutting thickness (mm)		Weight (g)
		Copper wire	Steel wire	
3	17	1	0.5	116
5	28	1.8	1.2	84



MATERIAL HANDLING

Vacuum suction cups

Technical description

- Use in various industries such as plastics, sheet metal, packaging, etc.
- Various suction cup designs – Flat, bellows, oval suction cups
- Large selection of suction materials

Abbreviated designation	Hardness [Shore A ± 5°]	Commercial designation	Trade name (example)	Working temperature short-term [°C]	Working temperature short-term [°F]	Abrasion resistance	Flexibility	Oil resistance	Fuel resistance	Ozone and weather resistance	Acid resistance	Alkaline resistance
BR-AS	60	Butadiene rubber antistatic		-50 / +100	-58 / +212	++	+	o	o	o	+	++
CR	50 - 60	Chloroprene	Neoprene®	-40 / +110	-40 / +230	+	+	++	o	++	+	+
EPDM	50		Vistalon®	-40 / +130	-40 / +266	+	++	o	o	++++	+++	+++
FKM	65	Fluororubber (FPM)	Viton®	-10 / +230	+14 / +446	o	o	++++	++++	++++	+++	+++
Sponge rubber							++++					
HNBR	55	Hydrogenated acrylic nitrile butadiene rubber	Therban®	-30 / +160	-22 / +320	++	+	++++	++	+++	+	+
NBR	50 - 60	Nitrile rubber	Perbunan®	-30 / +90	-22 / +194	+	+	+++	+	o	o	o
NBR-AS	50 - 70	Nitrile rubber antistatic		-30 / +90	-22 / +194	+	+	+++	++	o	o	+
NR	35 - 45	Natural rubber	SMR	-40 / +80	-40 / +176	++	++++	o	o	o	+	++
NR	50 - 65	Natural rubber	SMR	-40 / +80	-40 / +176	++	+++	o	o	o	+	++
PU	50 - 65	Polyurethane (EU/AU)	Urepan®	-20 / +80	-4 / +176	++	+	+++	++	+	o	o
PU	50	Polyurethane		10 / +50	+50 / +122	+++	++++	+++	+++	++	o	+++
SBR	50 - 60	Styrene-butadiene rubber	Buna®	-30 / +80	-22/+176	+++	++	o	o	+	+	+
SI	35 - 45	Silicone rubber	Elastosil®	-40 / +200	-40 / +392	o	++++	o	o	+++	o	o
SI	50 - 65	Silicone rubber	Elastosil®	-40 / +200	-40 / +392	o	+++	o	o	+++	o	o
Tepuflex®	50	Thermoplastic elastomer		0 / +60	+32 / +140	+++	++	o	o	+++	o	o
Thermalon®	60			0 / +160	+32 / +320	++	+	+++	++	o	+	+
Varioflex®	30/60	Polyurethane (2 Shore hardnesses)		10 / +50	+50 / +122	+++	++++	+++	+++	++	o	+++
Vinyl	50 - 55	PVC (soft)		0 / +60	+32 / +140	+++	++	+	+	++	++	++
Vulkollan®	75		Vulkollan®	-40 / +80	-40 / +176	++++	+	+++	++	+++	+	+

Depending on the application, vacuum suction cups are subject to mechanical and chemical stresses. Therefore, the data are only indicative. Special suction cups with a felt pad are low-impact; they can be used for temperatures up to max. 500°C (932°F) for a short period of time.

- + conditionally suitable
- ++ suitable
- +++ well suited
- ++++ perfectly suited
- o not suitable

MATERIAL HANDLING

For general industry



Designation	Shape	Dimensions from - to (mm)	Material	Special features
SFR	Suction ring	285 - 920	NBR	For very large loads
SFU-RT	Flat, round	160	NR	Separation of porous products
SO-E	Oval	10x4 - 30x8	NBR / SI	Slim design
SFPL-D	Flat, round	160 - 350	CR	Heavy-duty suction plate
SBPL-E	1.5 bellows, round	150 - 350	NBR / NR	Heavy-duty suction plate
SFU-S	Flat, round	30 - 225	Various	Safety sealing lip
SX-F	Flat, round	25 - 90	SI	Special felt support, up to 500°C; imprint-free
SP-PLM	Flat, round	35 - 200	EPDM	For highly textured surfaces
SFU-R	Flat, round	40 - 200	SBR / NBR / NR	For textured surfaces; with safety sealing lip
SP-BX1	1.5 bellows, round	11 - 160	Varioflex®	Composite material, sturdy body - soft sealing lip
SP-BX2	2.5 bellows, round	11 - 77	Varioflex®	Composite material, sturdy body - soft sealing lip
SP-BX2 PU50	2.5 bellows, round	11 - 77	PUR	-
SFU-S	Flat, round	30 - 225	NBR / SI / NR	-
SFU-A	Round	1.5 - 200	Various	-
SFU-D	Flat, round	5 - 85	Various	-
SBU 2	2.5 bellows, round	5 - 88	Various	-
SBU 3	3.5 bellows, round	18, 25	Various	-
SBU-VU	Round	9 - 62	Vulkollan®	-
SO-FU	Oval	4x2 - 100x35	Various	-
SO-BU	2.5 bellows, oval	25x8 - 75x25	NBR / SI	-
SP-F	Flat suction unit	5 - 155	Various	-
SP-B	Bellows suction cup	6 - 160	Various	Versatile use
SFU-F	Round	4 - 40	NBR / SI	Flexible lip
SBF-A	1.5 bellows, round	10 - 80	Various	Flexible lip
SBF-B	1.5 bellows, round	8 - 20	NBR / SI	Flexible lip
SFU-L	Round	9 - 25	Various	Long shaft
SO-Z	Oval	2x4 - 10x18	NBR / SI	Suitable for cylindrical products
SO-C	Oval	30x12 - 55x12	Various	High dynamics

For the packaging industry



Designation	Shape	Dimensions from - to (mm)	Material
SBV 1	1.5 bellows, round	5 - 70	Vinyl
SBV 2	2.5 bellows, round	6 - 50	Vinyl
SO-BV	2.5 bellows, round	6 - 50	Vinyl
SBF-C	4.5 bellows, round	10 - 50	NBR / SI

For the plastic industry



Designation	Shape	Dimensions from - to (mm)	Material
SKH-B1	1.5 bellows, round	5 - 43	HNBR
SKH-B2	2.5 bellows, round	5 - 42	HNBR
SKH-O	Oval	4x2 - 45x15	HNBR
SKT-B1	1.5 bellows, round	5 - 63	Thermalon®
SKT-B2	2.5 bellows, round	5 - 62	Thermalon®
SKT-O	Oval	4x2- 60x20	Thermalon®
SKT-F	Flat, round	5 - 95	Thermalon®

For the food industry



Designation	Shape	Dimensions from - to (mm)	Material	Special features
SL-B	Round	34 - 60	SI (FDA compliant)	Baked goods handling
SV-SB	1.5 bellows, round	16 - 40	SI (FDA compliant)	-
SV-RB	2.5 bellows, rectangular	52x25 - 80x50	SI (FDA compliant)	-
SL-PF	Round	16 - 22	SI (FDA compliant)	Praline handling

MATERIAL HANDLING

For the foil & paper industry



Designation	Shape	Dimensions from - to (mm)	Material	Special features
SD-F	Round	8 - 40	Various	–
SD-B	Bellows suction cup, round	17 - 47	Various	–
SD-MM	Flat suction unit	13 - 25	NR / Vulkollan®	Müller-Martini printing presses

For the wood & glass industry



Designation	Shape	Dimensions from - to (mm)	Material
SOPL-S (and -A)	Oval	110x40 - 580x180	NBR / NR

For the sheet metal & metal industry



Designation	Shape	Dimensions from - to (mm)	Material
SM-F	Flat, round	30 - 125	NBR (LABS free VDMA 24364 PKI A1)
SM-B	1.5 bellows, round	22 - 125	NBR (LABS free VDMA 24364 PKI A1)

Area grippers

Technical description

- For automated handling of individual products or product layers without changing grippers
- With built-in ejectors or with connection to central vacuum supply
- With flow valves or flow resistors
- The sealing foam can be replaced quickly, without being destroyed and without leaving residue
- Large-area grippers with flow valves are suitable for swivel/tilt movements up to less than 90°
- Equipped with vacuum gauge as standard
- Other sealing foams (height, shape) on request



Designation	Length (mm)	Width (mm)	Suction cells / vacuum cups (pc)
FSG with sealing foam	295 - 1265	130	53 - 263
FSG with vacuum suction cup Ø 40 mm	295 - 1265	130	17 - 80
FSG with vacuum suction cup Ø 20 mm	295 - 1265	130	53 - 263
SBX-F with sealing foam	460 - 1274	130 - 165	29 - 87
SBX-F with vacuum suction cup Ø 43 mm	460 - 1274	130 - 165	23 - 88

Vacuum generation

Technical description

- Heavy-duty ejectors, for harsh operating conditions
- Inline ejectors, compact and lightweight
- Multi-chamber ejectors, require little compressed air and offer high suction power
- Compact ejectors, take up little space and offer a variety of intelligent functions



Designation	Suction power at 4 bar (NI/min)	Final vacuum at 4 bar (%)
Heavy duty ejector*	30 - 130	85

* With blow-off connection.



Designation	Suction power at 5 bar (NI/min)	Final vacuum at 5 bar (%)
EIL inline ejector	8 - 28	60 - 85
FGS inline ejector	42 - 68	75 - 90
EBA compact ejector*	25	85

* With integrated blow-off function.



Designation	Suction power at 6 bar (NI/min)	Final vacuum at 6 bar (%)
FBM mini multi-chamber ejector	74 - 149	85
Standard multi-chamber ejector*	140 - 320	85
FMC multi-chamber ejector	360 - 1,650	80 - 92

* With blow-off connection.



Designation	Suction power at 5 bar (NI/min)	Final vacuum at 5 bar (%)
MFE compact ejector* modular system up to 5 ejectors, electric control, vacuum sensor, etc.	80 - 245	85

* With integrated blow-off function.

Electronics and sensors

Technical description

- Different versions of cables and plugs
- Sensors for different applications
- Various versions of signal distributors

Cables



Photoelectric sensor



Relay switch box





● Stäubli Units ○ Representatives / Agents

Global presence of the Stäubli Group

www.staubli.com